



# **THE BULLETIN 2022**

**INDUSTRIAL DESIGN REGISTRY  
INDUSTRIAL PROPERTY DIVISION  
DEPARTMENT OF INTELLECTUAL PROPERTY**

**Ministry of Economic Affairs, RGoB**

ID Bulletin No. 01

March 30, 2022

## CONTENTS

GENERAL INFORMATION AND NOTICES

OFFICIAL NOTICE

FEES

INDUSTRIAL PROPERTY ATTORNEYS/AGENTS

APPLICATION DETAILS

INVALIDATION

OFFICIAL WORKING HOURS OF THE REGISTRY

ENQUIRIES

INFORMATION CONTAINED IN THIS JOURNAL

REGISTERED INDUSTRIAL DESIGN

## GENERAL INFORMATION AND NOTICES

This Bulletin is published by the Registry of Industrial Designs in accordance with the Section 21 of the Industrial Property Act of Kingdom of Bhutan, 2001 and Rule 34 of the Industrial Property Rules, 2001.

### **Section 21 (IP Act of Kingdom of Bhutan, 2001)**

#### **Examination; Registration and Publication of Industrial Design**

21. (1) The Registrar shall accord as the filing date the date of receipt of the application, provided that, at the time of receipt, the application contains indications allowing the identity of the applicant to be established and the required graphic representation of the article embodying the industrial design. Section 11(1) (b) shall apply mutatis mutandis.

(2) After according a filing date, the Registrar shall examine whether the application complies with the requirements of Section 20(1) and (2) and the Rules pertaining thereto, whether the application fees has been paid and whether the industrial design complies with the requirements of Sections 17 and 18(3) and the Rules pertaining thereto.

(3) Where the Registrar finds that the conditions referred to in subsection (2) hereof are fulfilled, he shall register the industrial design, publish a reference to the registration and issue to the applicant a certificate of registration of the industrial design; otherwise, he shall refuse the application.

(4) (a) Notwithstanding subsection (3), where a request has been made under Section 20 (5) for deferment of publication, upon registration of the industrial design, neither the representation of the design nor any file relating to the application shall be open to public inspection. In this case, the Registrar shall publish a mention of the deferment of the publication of the industrial design and information identifying the registered owner, and indicating the filing date of the application, the length of the period for which deferment has been requested and any other prescribed particulars

(b) At the expiry of the period of deferment, the Registrar shall publish the registered industrial design.

## REGISTERED INDUSTRIAL DESIGN

(c) The institution of legal proceedings on the basis of a registered industrial design during the period of deferment of publication shall be subject to the condition that the information contained in the Register and in the file relating to the application has been communicated to the person against whom the action is brought.

### **Rule 34 (IP Rules, 2001)**

#### **34. Registration of Industrial Design; Publication of Reference Thereto; Issuance of Certificate**

(1) Subject to the payment of the registration and publication fee within the period prescribed in Rule 33(6), the Registrar shall register the industrial design in accordance with Section 21(3) and this Rule.

(2) The Registrar shall allot to each industrial design he registers a number in the sequential order of registration.

(3) The registration of an industrial design shall include a representation of the industrial design and shall specify:

- (i) the number of the industrial design;
- (ii) the name and address of the registered owner;
- (iii) the name and address of the agent, if any;
- (iv) the name and address of the creator, except where he has asked not to be named in the registration;
- (v) if the priority has been claimed, and the claim has been accepted, the priority date and the country or countries in which or for which the earlier application was filed; and
- (vi) the kind of products for which the industrial design is to be used.

(4) The publication of the reference to the registration of an industrial design, under Section 21

(5) shall contain the particulars specified in paragraph (3) hereof.

(6) The certificate of registration of an industrial design shall be issued on Form 6.

## REGISTERED INDUSTRIAL DESIGN

### OFFICIAL NOTICE

In accordance with the Industrial Property Act of Kingdom of Bhutan, 2001 and Industrial Property Rules, 2001

Preliminary

Section 1 to 3

Rule 1 to 8

Part III

Section 17 to 23 (Industrial Designs)

Rule 30 to 35

Part IV

Sections 34 to 44 (General Provisions as applicable to Part III)

Sd/-

REGISTRAR OF INDUSTRIAL PROPERTY

### FEES

Fees may be paid in cash or Bank drafts drawn on a local Bank, made payable the Registrar of Industrial Property. Until further notice the fees in cash may be paid at the Regional Trade & Industry Office, Changzamtog, Thimphu under the head “Fees for administration of Industrial Property Regulations (FAIPR)”

## INDUSTRIAL PROPERTY ATTORNEYS/AGENTS

Under section 35, read with Rule 60, the following persons are registered as Industrial Property Attorneys/Agents and are active currently:

- a. Mr. Prakash Rasaily, Clues and Colleague, Flat 1, Lhaki Shopping Center, Phendey Lam, P.O. Box 503, Thimphu-11001, BHUTAN  
Telephone: PABX (+975) 2325572/2335761, Fax: +9752325755,  
Direct: +9752321039, Mobile no.:+97517110908/77110908  
Email: cluesandcolleague@gmail.com
  
- b. Mr. Yishay Dorji, Yishay & Associates, Sernya Lam. P.O. Box 995, Thimphu, Bhutan  
Telephone- 00975-2325722, Mobile no.: +975 - 17114383  
Email: y.dorji57@gmail.com

## APPLICATION DETAILS

The number of the application is indicated before the date of filing, followed by the particulars of the applicant. The address for service in case of a foreign applicant is also given. The conditions/limitations subject to which the design is accepted are also indicated.

The registry applies the Locarno Classification System for classification of industrial designs and is indicated in the application.

## INVALIDATION

Notice is hereby given that, any person interested may, within three months from the date of this publication, give to the Registrar notice of Invalidation to the registration of the industrial design, on Form ID6 along with the prescribed fee.

As per Section 23(2) of the Industrial Property Act, the request for invalidation

shall prove that any of the requirements of Section 17 and 18 is not fulfilled or if the registered owner of the industrial design is not the creator or his successor in title.

### OFFICIAL WORKING HOURS OF THE REGISTRY

The official working hours of the office are as follows:

Monday to Friday : 0900 hours to 1300 hours  
Saturday, Sunday and Public Holidays: Closed

### ENQUIRIES

For enquiries relating to official notices and other information appearing in the Bulletin, please contact the Office at 02335233/326512 or at email address [sangaychoden@moea.gov.bt](mailto:sangaychoden@moea.gov.bt)

Information pertaining to Industrial Designs is also available at web sites: <http://www.ipbhutan.gov.bt> and at <http://www.moea.gov.bt>

All application, notices, statements or other documents or any fees required by the Industrial Property Act of Kingdom of Bhutan, 2001 and Rules therein will be received at the Department of Intellectual Property, Ministry of Economic Affairs, Royal Government of Bhutan, Thimphu.

### INFORMATION CONTAINED IN THIS JOURNAL

The Registry of Industrial Designs does not guarantee the accuracy of its publications, data records or advice nor accept any responsibility for errors or omissions or their consequences. Permission to reproduce extracts from this Bulletin must be obtained from the Registrar.

Following Internationally agreed Numbers for Identification of bibliographic Data (INID) relating to industrial designs are used:

- (11): Industrial Designs Number
- (21): Serial number of application/Application Number
- (22): Date of filing of application
- (29): Representation of the industrial design
- (31)(32)(33): Priority
- (45): Date of Publication
- (51): Locarno Classification of Industrial Designs
- (54): Designation of article(s) or product(s)
- (57): Description of characteristic features of industrial design including indication of colors
- (71): Name and address of the applicant
- (72): Name and address of the designer
- (74): Address for correspondence or agent



## **REGISTERED INDUSTRIAL DESIGN**

- (11) INDUSTRIAL DESIGNS NO. : D 000018  
(21) APPLICATION NO. : BT/D/2017/18  
(22) DATE OF FILING : NOV. 07, 2017  
(45) DATE OF PUBLICATION : MAR. 30 2022  
(51) CLASS AND SUB-CLASS : 15-03  
(54) ARTICLE(S)/PRODUCT(S) : Design of Rotary Tiller I

**(71) NAME AND ADDRESS OF APPLICANT(S):**

Siam Kubota Corporation Co., Ltd  
101/19-24 Moo 20, Navanakorn Industrial Estate,  
Klongluang District, Pathumtani Province  
Thailand

**(72) NAME AND ADDRESS OF DESIGNER(S)/CREATOR(S):**

1. Mr. kritchai Cojchaplayuk  
127 Moo 6 Maerumpueng Sub-district,  
Bangsaphan District, Prachuabkirikhan Province,  
77140, Thailand
2. Mr. Chairat Dee-eam  
53/48 Moo 13 Klongnueng Sub-district,  
Klongluang District,  
Pathumthani Province,  
12120, Thailand
3. Mr. Noppadol Trayangkul  
55/141 Moo 2, Lamphakut Sub-district,  
Thunyaburi District,  
Pathumtani Province, Thailand

**(74) AGENT:**

Clues & Colleagues, P.O. Box 503, Flat 3,  
Kuenga Sammphel Zhelyekhang, Babesa  
Thimphu, Bhutan

(29)

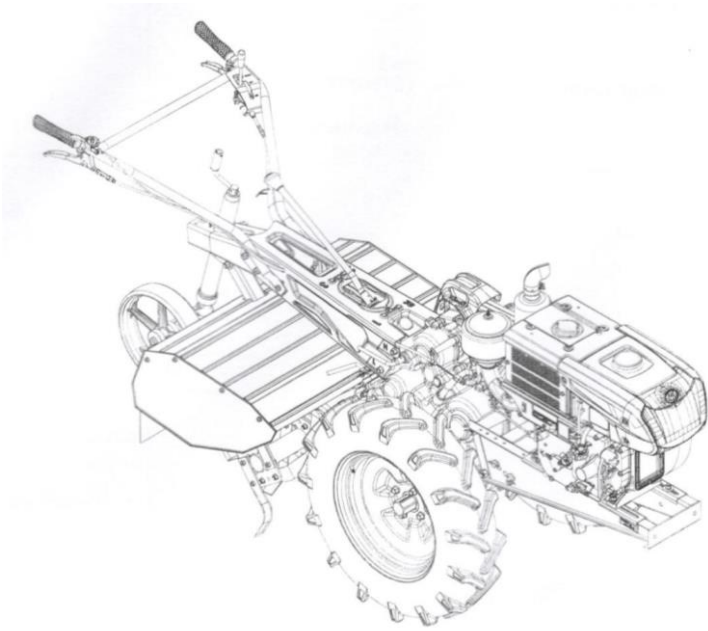

## **REGISTERED INDUSTRIAL DESIGN**

- (11) INDUSTRIAL DESIGNS NO. : D 000019  
(21) APPLICATION NO. : BT/D/2017/19  
(22) DATE OF FILING : NOV. 07, 2017  
(45) DATE OF PUBLICATION : MAR. 30 2022  
(51) CLASS AND SUB-CLASS : 12-16  
(54) ARTICLE(S)/PRODUCT(S) : Design of a  
Wheel

**(71) NAME AND ADDRESS OF APPLICANT(S):**

Siam Kubota Corporation Co., Ltd  
101/19-24 Moo 20, Navanakorn  
Industria Estate  
Klongluang District, Pathumtani Province  
Thailand

**(72) NAME AND ADDRESS OF DESIGNER(S)/CREATOR(S):**

1. Mr. kritchai Cojchaplayuk  
127 Moo 6 Maerumpueng Sub-district,  
Bangsaphan District, Prachuabkirkhan  
Province,  
77140, Thailand
2. Mr. Chairat Dee-eam  
53/48 Moo 13 Klongnueng Sub-district,  
Klongluang District,  
Pathumthani Province,  
12120, Thailand
3. Mr. Noppadol Trayangkul  
55/141 Moo 2, Lamphakut Sub-district,  
Thunyaburi District,  
Pathumtani Province, Thailand

**(74) AGENT:**

Clues & Colleagues, P.O. Box 503, Flat 3,  
Kuenga Sammphel Zhelyekhang, Babesa  
Thimphu, Bhutan

(29)

